

## Contents:

	Page
Advice to owners of EPIRBs.....	1
The COSPAS-SARSAT satellite aided rescue system.....	2
Safety Alert Model: SA1G.....	3
When a distress situation occurs.....	4
In the event of inadvertent Activation.....	4
Beacon test procedure .....	5-6
Instruction for use in water.....	7
Instruction for use on land.....	8
To switch OFF.....	7-8
Helpful operation and information notes.....	9
Registration contacts.....	10
Product Warranty .....	11
Battery replacement and servicing.....	11
Specifications.....	12
Beacon installation.....	13

## Owners details

Name:
Address:
Phone:
Hex ID (as printed on beacon)

## Advice of EPIRB purchase or transfer

Registration of 406 Mhz satellite EPIRBs with the Registration Section of the Australian Maritime Safety Authority (AMSA) or Rescue Co-ordination Centre New Zealand (RCCNZ) is mandatory because of the global alerting nature of the COSPAS-SARSAT system.

The information provided in the registration is used only for search and rescue purposes.

Fill in the owner registration card immediately upon completion of the sales transaction. Register on-line, mail, fax or email the registration card to the Australian Maritime Safety Authority (AMSA) or Rescue Co-ordination Centre New Zealand (RCCNZ) immediately. Registration cards are also available on-line, visit [www.amsa.gov.au/beacons](http://www.amsa.gov.au/beacons)

If the beacon is to enter service immediately, complete the registration card, register on-line, mail, fax or email the information to the Australian Maritime Safety Authority (AMSA) or Rescue Co-ordination Centre New Zealand (RCCNZ).

If the beacon is being transferred to a new owner, the current owner is to inform the Australian Maritime Safety Authority (AMSA) or Rescue Co-ordination Centre New Zealand (RCCNZ) by email, facsimile, letter, telephone or on-line of the name and address of the new owner.

The new owner of the beacon is required to provide the Australian Maritime Safety Authority (AMSA) or Rescue Co-ordination Centre New Zealand (RCCNZ) with the information as shown on the registration card.

This obligation transfers to all subsequent owners.

## The COSPAS-SARSAT Satellite aided rescue system

COSPAS-SARSAT is an international (global) search and rescue system that uses satellites to detect and locate 406MHz emergency beacons carried by vessels, aircraft, or individuals.

The system consists of a network of satellites (polar orbiting and geostationary), ground stations, called Local User Terminal (LUT), Mission control centre (MCC) and rescue coordination centres.

When an EPIRB is activated, the 406MHz signal may be received by a satellite, the signal processed and data with position and digital message then re-transmitted either in real-time or stored. The signal is continuously down loaded until the satellite is in view of a LUT, when the LUT receives satellite data it's directly forwarded to MCC. The Rescue Co-ordination Centre who may arrange the search and Rescue using appropriate SAR organisations in the vicinity of the distress location.

The **Safety Alert** EPIRB homing signal (121.5MHz) allows SAR aircraft and boats to "home" directly to the signal using radio direction finders.

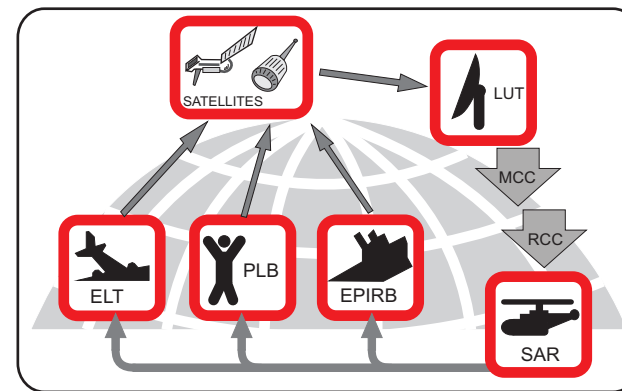

Page 1

Page 2

## When a DISTRESS situation occurs

**Only operate in a grave and imminent danger situation. (Non-emergency operation carries a severe penalty.)**

A mariner, aviator or individual in distress has several options to alert authorities when in need of assistance and to help them and Search and Rescue (SAR) Forces to locate the precise distress position.

If two-way, HF, MF, VHF or other radio's or even a mobile phone are available, they should be used immediately to contact authorities. If contact cannot be made by two-way radio communications and all other distress procedures fail to summon assistance and there is a grave and imminent danger situation, then the **Safety Alert** EPIRB should be deployed to alert authorities to the emergency and provide an accurate distress position.

Should the EPIRB be activated other than for a test, we recommend the EPIRB be removed from service and returned to Kinetic Technology International Pty Ltd. for battery replacement.

## In the event of INADVERTENT ACTIVATION

If the beacon is inadvertently turned ON, return switch to centre **OFF** position and rotate Switch Lock back to centre position.

**Immediately** inform the nearest search and rescue (SAR) authority or the Rescue Co-ordination Centre (RCC) in Australia, toll free on: 1800 641 792 or Aviation: 1800 815 257

or in New Zealand the Rescue Coordination Centre New Zealand (RCCNZ), toll free on 0508 472 269

Page 4

## Beacon Test Procedure

**To prevent inadvertent activation: Under no circumstances rotate Switch Interlock during TEST. (Non-emergency operation carries a severe penalty.)**

Beacon testing should be limited to no more than once per month as each test consumes valuable battery power and transmits signals to satellites.

Visually inspect the beacon for signs of physical damage and verify the red breakable "Emergency use only" seal on top the switch interlock is intact. Check the "Replace battery by" date has not expired. Should the seal be broken, the battery time expired or the beacon fail subsequent test, return to Kinetic Technology International Pty. Ltd. For service.

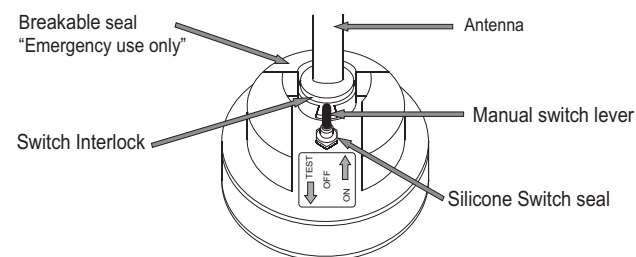

**Beacon test:** (Warning do not rotate Switch Interlock)

Release antenna from mounting bracket to upright position, move the TEST/ON-OFF switch lever, away from antenna for approximately **one second**. You will feel a click in the switch and the SA1G will beep once, then release the switch lever. The SA1G then completes it's test cycle and if successful the white strobe light will flash. Carefully place antenna back into stowed position on mounting bracket.

The test pass confirms the EPIRB is functioning at the time, but does not necessarily confirm remaining battery capacity. It is therefore important that the "Replace battery by" date be checked. For safety tolerances this is at half the nominal shelf life of the battery.

Page 5

## Beacon Test Procedure (continued)

**Warning:** The optional test GPS fix will consume battery power and to ensure maximum battery life the GPS test should not be conducted more than **two times per year**. If tested repeatedly, over time, the test function will be locked.

Before testing ensure beacon is positioned out doors in an open area with a clear unobstructed view of the sky to maximise satellite acquisition and avoid testing during poor weather conditions, i.e. Heavy precipitation.

**Note:** Testing maybe terminated at any time by moving the TEST/ON-OFF switch lever, away from antenna and releasing. (Test switch spring loaded and returns to OFF if released)

**Optional test GPS fix:** (Warning do not rotate Switch Interlock)

Move the TEST/ON-OFF switch lever, away from antenna for approximately six seconds. You will feel a click in the switch and the SA1G will beep twice, then release the switch lever. Beeps maybe heard during GPS test for approximately one minute and if successful strobe light will flash.

**Note:** A switch interlock at aerial base prevents the SA1G EPIRB from being accidentally activated. The switch interlock "Emergency use only" seal will be broken when rotating the switch interlock before permitting activation. It is in the owner's interest to ensure that this seal remains intact to remove any doubt as to whether the beacon has been operated causing reduction of battery life.

Page 6

## Safety Alert model: SA1G

The **Safety Alert** EPIRB model: SA1G is a compact, buoyant, self-contained emergency radio transmitter. When activated it will emit a distinctive digital radio signal on the 406MHz international distress frequency and a 121.5MHz homing signal for 48 hours minimum.

Since February 2009 any Emergency Position Indicating Radio Beacon (EPIRB) sold or manufactured in Australia must be satellite compatible and will therefore be capable of being detected by the **COSPAS-SARSAT** satellite aided Search and Rescue System.

The **Safety Alert** beacons have been designed and manufactured in Australia and approved to the exacting performance specification: AS/NZS 4280.1-2003, 406MHz satellite distress beacon, class 2.

With the EPIRB securely positioned in the mounting bracket an area is provided for the registration sticker which is supplied when the EPIRB is registered.

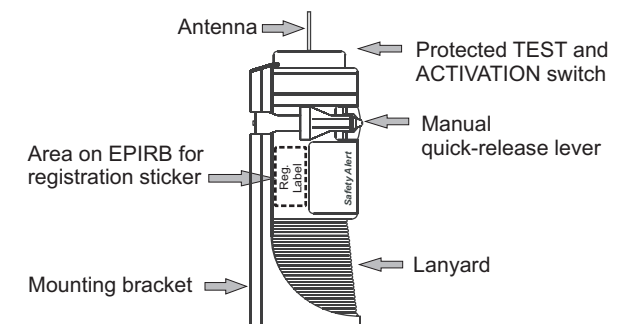

Page 3

## INSTRUCTIONS FOR USE IN WATER

1. Remove **Safety Alert** from stowage (mounting bracket).
2. Unwind lanyard from **Safety Alert** and attach free end of lanyard to life jacket or survival craft.
3. Rotate Switch Interlock in either direction, breaking the "Emergency use only" seal in the process.
4. Push switch lever to "ON" position (towards the antenna), switch will remain on. White strobe light flash and audible tones sound.
5. Deploy the beacon to the water and allow to float away from persons and objects to extent of lanyard.
6. Leave beacon operating continuously until rescued.

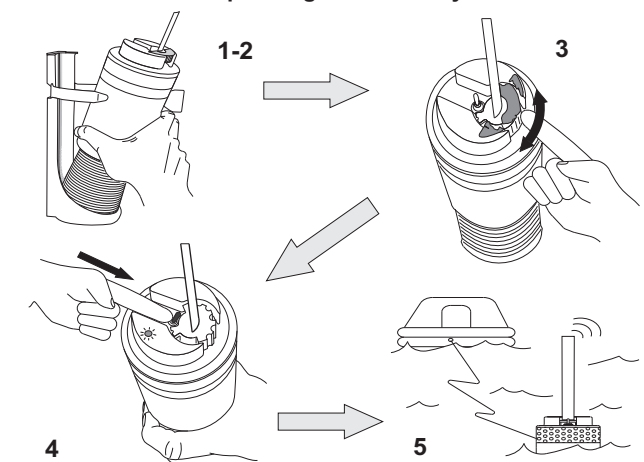

## To switch OFF

1. Move switch lever to centre "OFF" position.
2. Rotate "switch interlock" to align tab with switch lever, this will help to prevent the beacon from being accidentally activated.

Page 7

## Distributor Details



Kinetic Technology International Pty. Ltd.  
1 Kembla street, Cheltenham, Victoria, 3192  
Australia.  
Tel: 61 3 9583 9566 Fax: 61 3 9583 9805  
ABN 50 058 419 695

internet: [www.kti.com.au](http://www.kti.com.au) © K.T.I. Pty. Ltd. 2010  
E-mail: [info@kti.com.au](mailto:info@kti.com.au) NME30810G

Page 14

## Registration contacts

**Australian coded beacons**, address all correspondence to:  
Beacon Registration Section,  
Australian Maritime Safety Authority  
GPO Box 2181 Canberra City ACT 2601

Fax: International +61 2 9332 6323 Local 1800 406 329  
Phone: International +61 2 6279 5766 Local 1800 406 406

On-line registration: [www.amsa.gov.au/beacons](http://www.amsa.gov.au/beacons)  
Email: [ausbeacon@amsa.gov.au](mailto:ausbeacon@amsa.gov.au)

**New Zealand coded beacons**, address all correspondence to:  
Rescue Co-ordination Centre New Zealand  
PO Box 30050, Lower Hutt 5040  
Fax: International +64 4 577 8041 Phone +64 4 557 8033  
Email: [406registry@maritimenz.govt.nz](mailto:406registry@maritimenz.govt.nz)

All information subject to change without notice or obligation.

Page 10

## INSTRUCTIONS FOR USE ON LAND

1. Remove **Safety Alert** from stowage (mounting bracket).
2. Rotate Switch Interlock in either direction, breaking the "Emergency use only" seal in the process.
3. Push switch lever to "ON" position (towards the antenna), switch will remain on. White strobe light flash and audible tones sound.
4. Place the **Safety Alert** in a clear area away from persons or objects with the beacon/aerial in a vertical position.
5. **Leave beacon operating continuously until rescued.**

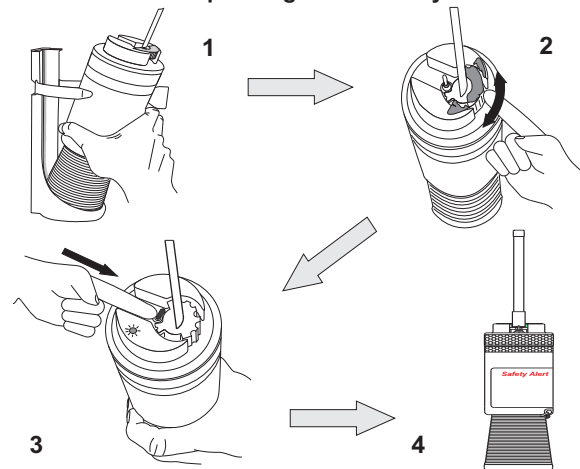

## To switch OFF

1. Move switch lever to centre "OFF" position.
2. Rotate "switch interlock" to align tab with switch lever, this will help to prevent the beacon from being accidentally activated.

Page 8

## PRODUCT WARRANTY

The "Safety Alert" EPIRB model SA1G is covered by manufacturer's warranty valid for 10 years from date of purchase. This Warranty covers labour and materials: all freight charges are to be borne by the purchaser. In the event of any claim under this Warranty, please arrange the return of the EPIRB to Kinetic Technology International Pty Ltd. 1 Kembla street, Cheltenham, Victoria, Australia 3192, either direct or through supply dealer, together with your proof of original purchase date. This Warranty does not exclude any conditions and remedies you may have under the Australian Consumer Law (ACL). Our goods come with guarantees that cannot be excluded under the Australian Consumer Law. You are entitled to a replacement or refund for a major failure and for compensation for any other reasonably foreseeable loss or damage. You are also entitled to have the goods repaired or replaced if the goods fail to be of acceptable quality and the failure does not amount to a major failure.

## Battery replacement and servicing

The **Safety Alert** EPIRB is fitted with special lithium batteries and it is therefore not possible to replace batteries in the field. Battery replacement and servicing of the beacon is carried out by Kinetic Technology International Pty. Ltd. (KTI) at their premises. Unless the beacon has been activated, battery replacement should only occur at ten yearly intervals. Kinetic Technology International Pty Ltd (KTI) conduct full mechanical and operational testing when replacing the batteries in accordance with specifications.

DO NOT incinerate beacon.  
DO NOT short circuit the battery or cells.

All information subject to change without notice or obligation.

Page 11

## Helpful operating and information notes

The **Safety Alert EPIRB** is most effective (i.e. has maximum range) when floating in water or placed on a clear elevated area. Metal objects or people in the immediate vicinity of the **Safety Alert** can distort the radiation pattern of the radio signal, it is therefore desirable to have the transmitting beacon a few metres clear of such objects. The lanyard is designed to be attached to a life jacket or survival craft, it should not be used to secure the beacon to fixed structures i.e. vessel or aircraft. It is not recommended to operate an EPIRB inside a life raft or under any cover or canopy. To view the test/activation strobe light in bright sunlight, it may be necessary to shade it with your hand. It is recommended the EPIRB be mounted with bracket supplied in an upright or horizontal position and easily accessible by all personnel at all times.

### Cleaning your EPIRB if required:

Care should be taken not to damage the aerial seal or inadvertently activate the beacon when cleaning. Visually inspect the beacon for any physical damage, (ie. Cracks in the case or silicone switch seal) which could allow moisture ingress and cause a malfunction. Only wipe the EPIRB with a damp cloth. Do not use chemicals.

### Photosensitive Seizures:

A very small percentage of people may experience a seizure when exposed to certain visual images, including flashing lights. Even people who have no history of seizures or epilepsy may have an undiagnosed condition that may cause these "photosensitive epileptic seizures" while watching an EPIRB.

These seizures may have a variety of symptoms, including light-headedness, altered vision, eye or face twitching, jerking or shaking of arms or legs, disorientation, confusion, or momentary loss of awareness. Seizures may also cause loss of consciousness or convulsions that lead to injury from falling down or striking nearby objects. Immediately stop looking at strobe light and consult a doctor if you experience any of these symptoms.

### RF exposure:

Due to transmitted RF power requirements for EPIRBs, Australian standards recommend where practical to minimise exposure by keeping more than 20cm from an EPIRB which has been activated.

Page 9

## SPECIFICATIONS

<b>Frequencies:</b>	406.037 MHz and 121.5 MHz (homing signal).
<b>Approvals:</b>	Australian and New Zealand AS/NZS 4280.1 TAC: 221 (Manual Activation)
<b>COSPAS-SARSAT:</b>	Fully compatible. C/S T.001 Class 2
<b>GPS:</b>	GPS receiver accuracy: 1.8m (CEP) 95. Type receiver: GPS L1 C/A-code, SPS. GPS aerial: L1-band
<b>Homing signal:</b>	Homing signal Amplitude Modulated, down swept tone.
<b>Activation:</b>	Manual switch with Test facility and Indicator light.
<b>Solid-state Strobe:</b>	Greater than 1cd effective intensity.
<b>Transmission Time:</b>	48 hours minimum.
<b>Batteries:</b>	Long-life lithium LiFeS <sub>2</sub> , Factory replaceable only. Replace battery prior to expiry date shown on beacon.
<b>Lanyard:</b>	8 metres max. UV, high density polyethylene twine.
<b>Antenna:</b>	Flexible marine grade stainless steel.
<b>Mounting Bracket:</b>	Quick manual release, rustproof, UV stabilised polypropylene
<b>Dimension:</b>	Diameter 80mm. Height 280 mm mounted in bracket.
<b>Weight:</b>	Gross weight 860 grams approx.
<b>Immersion:</b>	Watertight to a depth greater than 5 metres

**Operating Temperature:** -20° C to +55 °C  
**Storage Temperature:** -30° C to +70 °C

Page 12

# Safety Alert

## 406MHz EPIRB

Model: SA1G GPS version

## Instruction Manual

Emergency  
Position  
Indicating  
Radio  
Beacon

COSPAS-SARSAT  
Satellite compatible  
International  
Distress  
Frequencies



**Proudly designed and manufactured by:**  
Kinetic Technology International Pty. Ltd.  
1 Kembla street, Cheltenham, Victoria, 3192  
Australia.

internet: [www.kti.com.au](http://www.kti.com.au) e-mail: [info@kti.com.au](mailto:info@kti.com.au)

## Beacon Installation

Your Safety Alert EPIRB is supplied with a manual quick-release mounting bracket which is designed to be mounted upright or horizontal, on secure bulkhead or vessel structure.

The beacon bracket has eight countersunk 5.5mm dia. holes in different locations for a versatile mounting preference, only four holes may be required depending on fastening screws or bolt size.

Recommended fasteners to have countersunk head as not to damage the beacon when repositioned in bracket after installation.

### When installing the beacon consider carefully location.

- Easily accessible by all personnel at all times.
- Avoid prolonged exposure to sun light and salt water.
- Avoid exposure to extreme heat from engines and fuel/fumes.
- Avoid areas where personnel or machinery may cause physical damage to beacon.
- Beacon is NON magnetic and does not contain magnets however provide sufficient mounting distance from compass.

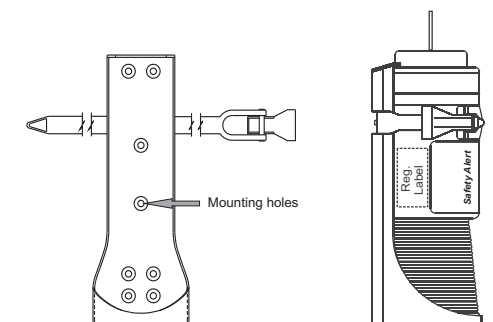

Page 13